

16. Solar refrigerator

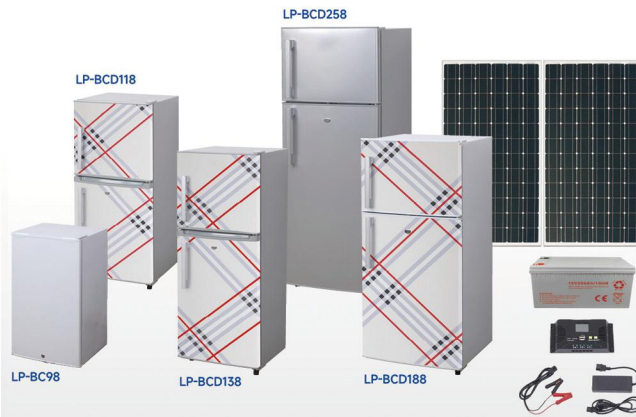

PRODUCT FEATURES:

1. High quality DC compressor
2. Works with both 12/24 volt systems (auto recognition)
3. Does not require an inverter
4. Adjustable heavy-duty glass shelves, bottom crisper
5. Interior led light
6. Optional Adaptor to run on AC power
7. Model LP-BCD188&LP-BCD258, please choose 24Volt systems connection



12V Solar system connection diagram

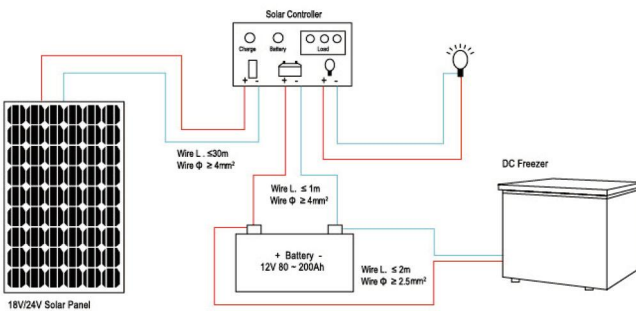

24V Solar system connection diagram

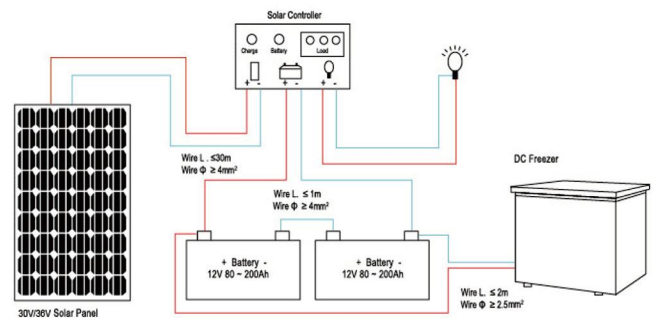

MODEL	LP-BC98	LP-BCD118	LP-BCD138	LP-BCD188	LP-BCD258
Rated Voltage	DC 12/24V	DC 12/24V	DC 12/24V	DC 12/24V	DC12/24V
Rated power	48W	55W	55W	66W	80W
Total Storage Capacity	90L	88L	105L	180L	213L
Freezing Volume	10L	36L	36L	45L	45L
Cooling Volume	80L	52L	69L	135L	168L
Defrost type	Manual defrost	Manual defrost	Manual defrost	Manual defrost	Manual defrost
Condenser	outside	outside	outside	outside	outside
G.W/N.W (KGS)	21.5/20	24.5/22	26/23	38/34.5	41/37.7
Product Dimension(mm)	473x455x836	453x465x1046	453x465x1193	548x560x1228	548x560x1423
Carton Dimension(mm)	515X465x861	530x510x1080	530x510x1234	580x590x1270	580x590x1465
Foam Thickness	60mm	60mm	60mm	80mm	80mm
40'HQ loading (PCS)	300	228	184	160	144